

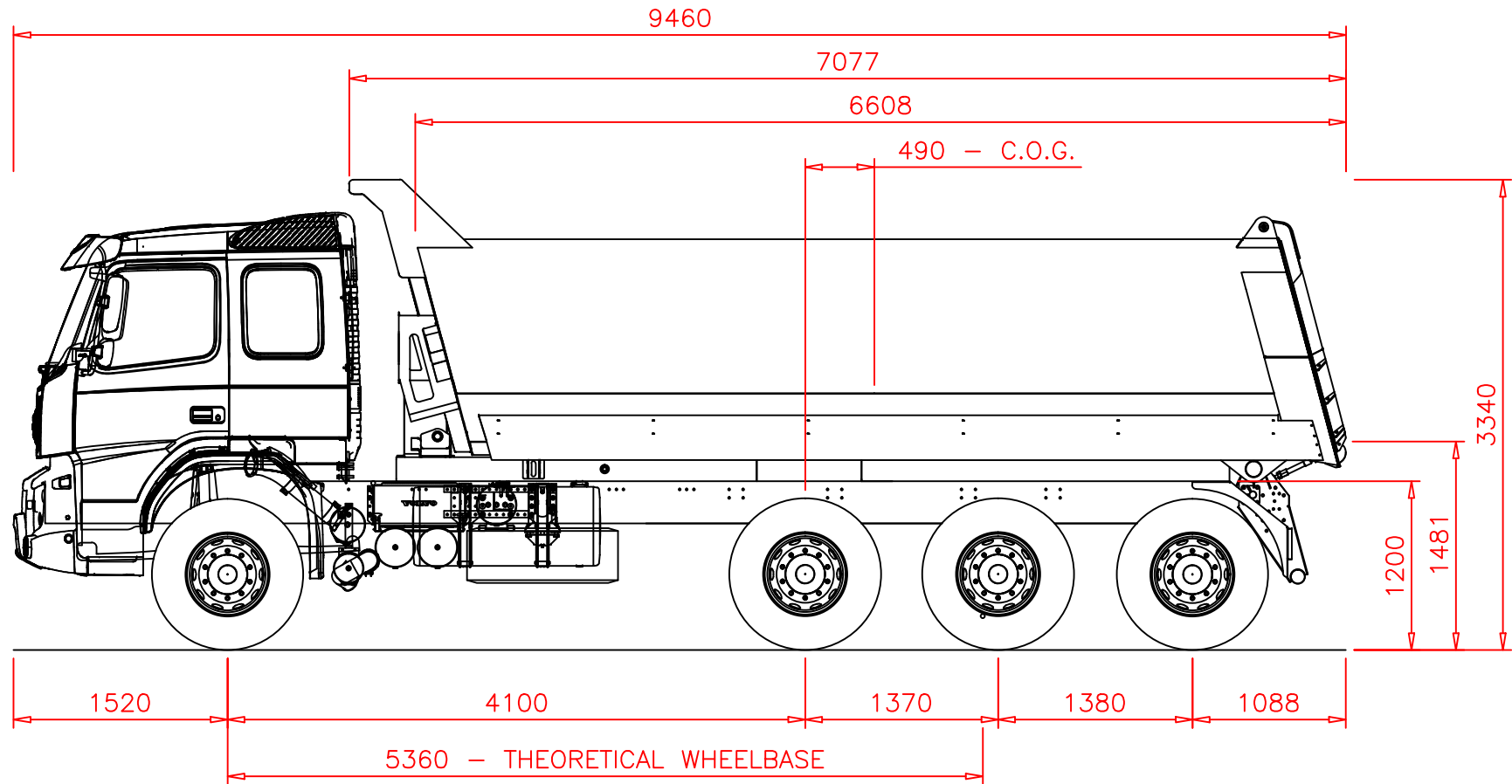

PAYLOAD = 17580
 BODY + HYDRAULIC TARE MASS = 4000 ESTIMATED
 GROSS BODY MASS = 21580



4600 = TRUCK TARE AT AXLES = 5520
 7700 = GROSS MASS AT AXLES = 24000

PAYLOAD = 17580kg
 GROSS VEHICLE MASS = 31700kg

REVISION				 TRAILERS (PTY) LTD design@roadhogtt.co.za COPYRIGHT <small>THIS DRAWING IS CONFIDENTIAL AND THE PROPERTY OF ROADHOG TRAILERS AND MAY NOT BE COPIED, REPRODUCED OR PASSED ON TO ANY THIRD PARTY WITHOUT THEIR WRITTEN CONSENT.</small>	NAME	DATE	TITLE:
					DJO	17/8/16	TIPPER VOLVO 18 CUBE HARDOX
REV	DATE	BY	REVISION DESCRIPTION	CHECKED			
				SCALE:	ALL DIMENSIONS, MASSES AND PAYLOADS ARE ESTIMATES AND EXCLUDE OPTIONAL EXTRAS.		DRAWING No: 1SHT 1 OF TPS18-01-0001
				N.T.S.			