

PAYLOAD = 7060  
 BODY + HYDRAULIC TARE MASS = 2000 (ESTIMATED)  
 GROSS BODY MASS = 9060

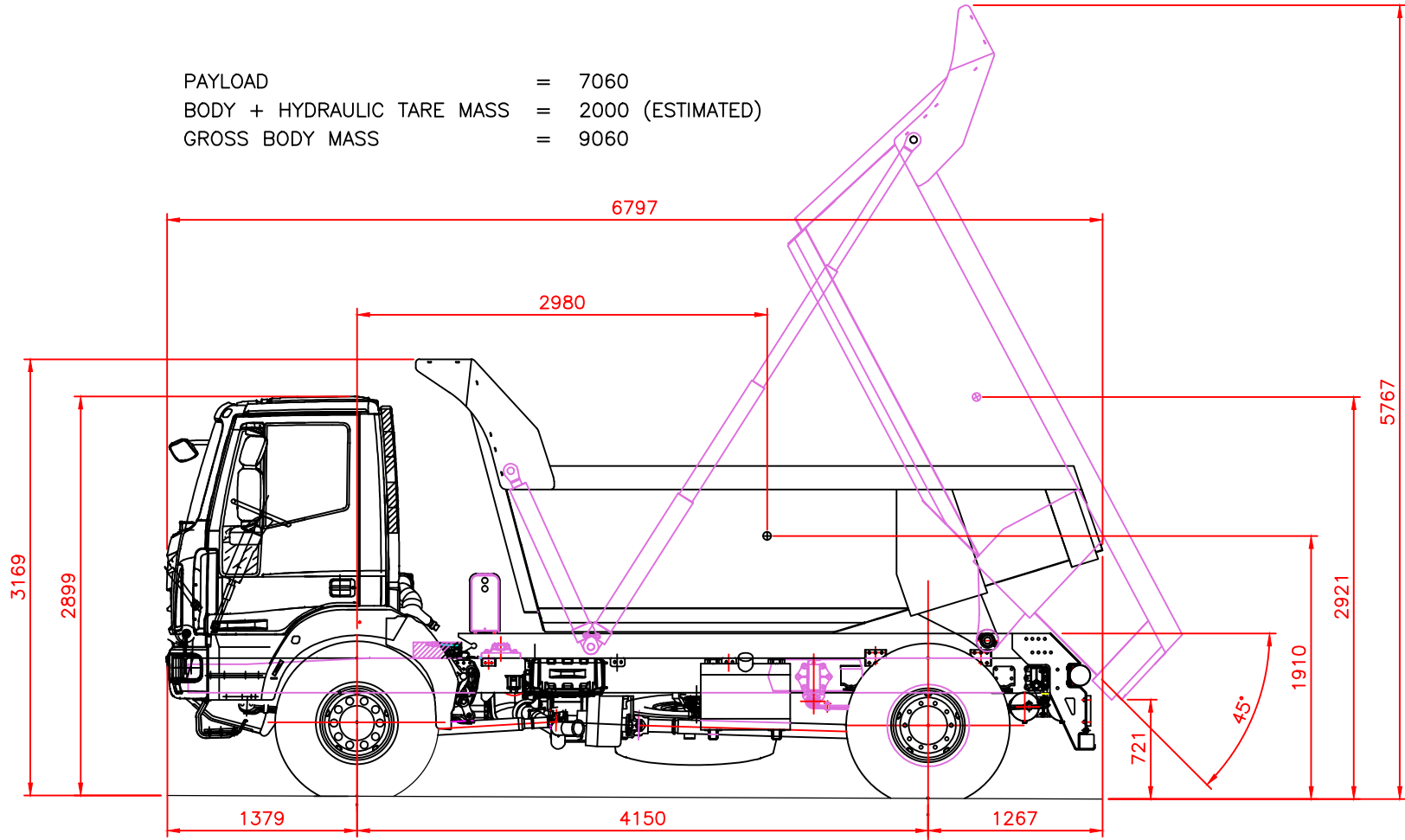

3880 = TRUCK TARE AT AXLES = 2060  
 6435 = GROSS MASS AT AXLES = 8565 (+0.76%)  
 6500 = PERMISSIBLE MASS AXLES = 8500

PAYLOAD = 7060kg  
 GROSS VEHICLE MASS = 15000kg

REVISION				<b>ROADHOG</b> TRAILERS (PTY) LTD design@roadhogtt.co.za	NAME	DATE	TITLE: 8 CUBE DUMPER ROUND HARDOX ON IVECO 4X4 150E24
					DRAWN	L V	
				CHECKED			
				SCALE: N.T.S.		ALL DIMENSIONS, MASSES AND PAYLOADS ARE ESTIMATES AND EXCLUDE OPTIONAL EXTRAS.	DRAWING No: TSHT 1 OF TIVE-01-0001
REV	DATE	BY	REVISION DESCRIPTION	<small>THIS DRAWING IS CONFIDENTIAL AND THE PROPERTY OF ROADHOG TRAILERS AND MAY NOT BE COPIED, REPRODUCED OR PASSED ON TO ANY THIRD PARTY WITHOUT THEIR WRITTEN CONCENT.</small>			